

User Guide

Ingenico 7780



Secure transaction and payment solutions

Secure transaction solutions For everyone everywhere

i5000

Countertops

The top seller in the world
Compact and easy to use



i7000

Indoor Wireless

Bluetooth, Wi-Fi, GPRS
Convenience and comfort



i8000

Outdoor Wireless

GSM, GPRS, CDMA

All your business on a terminal
Ruggedized, bar code reading,
finger print capture,
touch screen, text to speech...



i6000

Interactive PIN Pads

Signature capture
Touch screen
Interactive advertising



i3000

PIN Pads

Fast and easy way to upgrade
your existing POS system to
accept EMV payments



i2000

Check readers

Fast and easy processing of
checks
Reduced fraud



i9000

Unattended

Full EMV solution
GPRS ready
Separate components for
easy integration



EMV APPROVED[®]



UNICAPT 32

The common secure platform to
all our product range

+33 (0)1 46 25 82 00

www.ingenico.com

The ingenico logo, featuring a stylized key icon and the text "ingenico" in a bold, lowercase font.

Contents

1	Presentation	5
1.1	Overview of Ingenico 7780	6
1.2	Keyboard details and functionality	7
2	Use.....	9
2.1	Card reading	11
2.2	Terminal maintenance	11
2.3	Changing the roll of paper	12
3	Installation and starting.....	13
3.1	Location of the terminal and the base.....	13
3.2	Battery set up and charging.....	14
3.3	Terminal connections.....	16
3.4	Installing a SIM card and a full format card.....	19
3.5	Troubleshooting	21
4	Recommendations	23
4.1	Security.....	23
4.2	Safety	23
4.3	Switched Telephone Network (STN).....	24
4.4	RF Safety.....	24
4.5	General safety	24
4.6	WEEE	25
5	Index.....	26

Thank you for choosing an INGENICO product !

We hope that you will be fully satisfied with your new terminal. In order to fully meet the requirements of our different customer users, the new Ingenico terminal comes in different models:



Ingenico 5100 – countertop



Ingenico 5300 – hand over



Ingenico 7300 – portable

Your model, the Ingenico 7780 is a **portable Bluetooth technology** terminal; **Effective**, processor 32-bits inside; **Highly secured**, EMV level 2 certified.

Ingenico 7780 features a new ergonomic design that provides a friendly interface for the user:

- "Easy loading" printer to load paper easier and quicker,
- Large graphic display with adjustable contrast,
- Fast communications.

The environment is also a priority for Ingenico:

- Lighter packaging,
- Use of non-toxic products,
- Recyclable plastics.

Please read this manual to understand and make the best use of your terminal.

It presents the terminal and its different characteristics, offers quick and easy use and finally describes a standard terminal installation (from unpacking to starting for the first time).

Furthermore, the manual features a contents table and an index at the end of the manual for easy reference for specific needs, such as changing the roll of paper.

i *The manual describes a terminal without application software. A separate manual will be supplied for each application installed. Certain connection options presented in this manual can differ according to which model you possess.*

⚠ **This symbol indicates an important warning.**

i *This symbol indicates a piece of information.*

1 Presentation

Ingenico 7780 is an electronic payment terminal designed to accept payment using magnetic stripe and smart cards.

The terminal box contains:



The terminal and base



The power supply unit

- ⚠ **The power supply unit supplied is specially designed for the terminal. Do not use any other unit.**



The telephone cable and plug

- This manual
- The EC compliance booklet
- A cable securing plate and a screw

- ⚠ **The model of the power supply unit and the telephone cable and plug depend on the country.**

1.1 Overview of Ingenico 7780

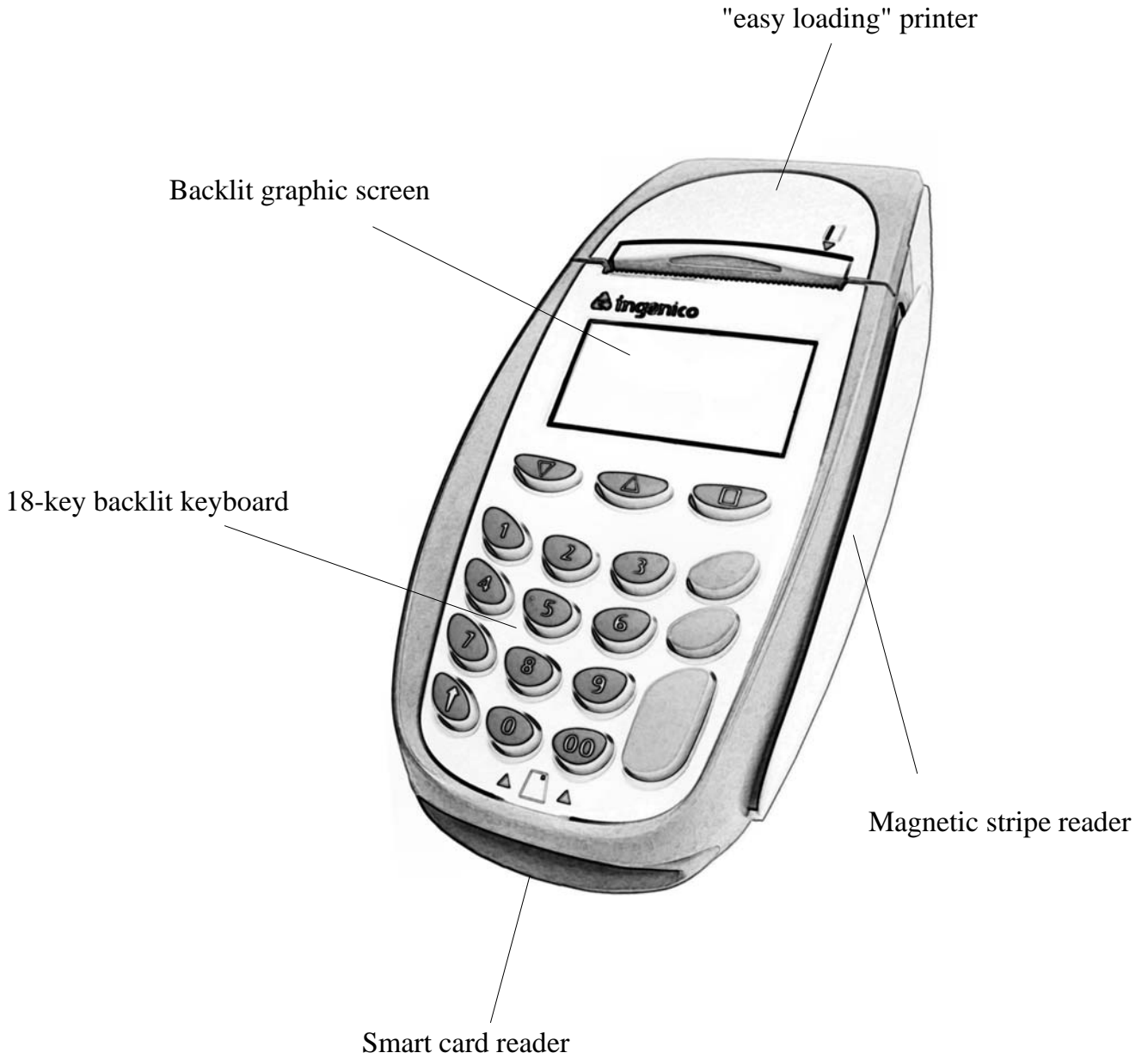

1.2 Keyboard details and functionality

This chapter describes the key functions for a terminal with no specific application.

i *Some keys can have other functions according to the applications that are present in the terminal.*

The **navigation keys** navigate in the terminal menus

The **function key** accesses the different system and application menus

The **red key** cancels the procedure in progress, goes into stand-by and switches the terminal off away from the base

Digital keyboard

The **yellow key** cancels the last character

The **green key** validates the input selections and information, turns on the terminal

The **arrow key** advances the paper a few centimetres

The **00 key** goes directly from euros to cents and from cents to euros

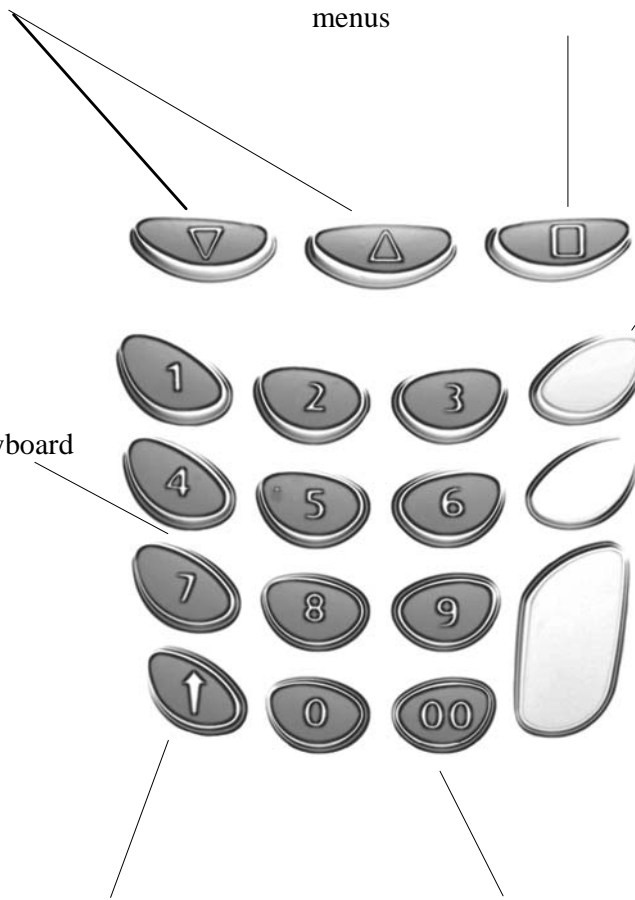

2 Use

In this chapter, we consider that the terminal has been installed (battery charged with a maximum charge level), connected to the electricity and telephone network and initialised. For the installation (connections and battery charging) refer to chapter 3 “Installation and starting”.

 **Before to use the terminal, always check if the roll of paper is present !**

Terminal display ready to carry out a transaction

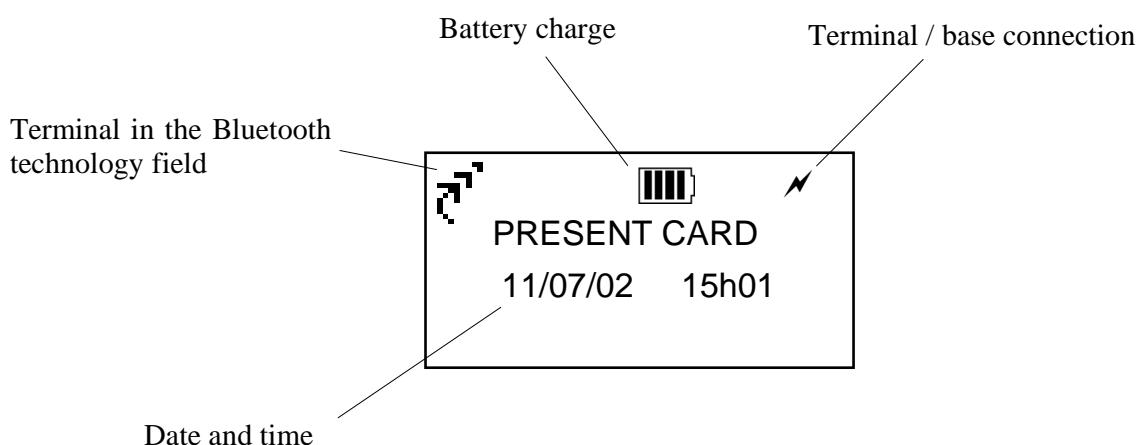

In order to extend battery life, the Ingenico 7780 terminal goes automatically into stand-by^{*} after a few dozen seconds when it is not on the base.

The terminal comes back on if:



- it is placed on the base,
- the green key is pressed.

** This option will depend on the application installed in the terminal.*



Ingenico 7780

Because of the Bluetooth technology transmission it is not necessary to place the terminal on the base to use the serial link, the modem or to perform an authentication.

The symbol *  on the upper left hand corner of the screen indicates that the terminal is assigned to its base and that it is in the Bluetooth technology field (the research phase last typically less than 10s).

The message *  **-RANGE-**  appears when the Bluetooth technology link is not available:

- the terminal is out of range of its base
- the terminal assignment operation to its base has not been carried out.

The message *  **-BUSY-**  appears when the terminal tries to connect to a base already connected with another terminal. In this case, wait until the base is free.

* *This option will depend on the application installed in the terminal.*

2.1 Card reading

Magnetic stripe card

The card can be read either from bottom to top or from top to bottom, with the stripe facing the terminal.

Use a regular movement in order to ensure a reliable card reading.

Smart card

Insert the card horizontally with the metal chip facing upwards and leave in position throughout the transaction.



2.2 Terminal maintenance

🔌 Make sure the terminal is off for all cleaning operations.

- Do not clean the terminal with water but with a dry or only slightly damp cloth.
- Do not use solvent, detergent or abrasive products.
- If the terminal has battery recharging problems or in the event of remote data collection or authorisation communication problems (the message <<No tone>> is printed out when you try to connect), clean the golden contact under the terminal with a damp cloth.
- Do not scratch or scrape the golden surface of the contacts.

2.3 Changing the roll of paper

Ingenico 7780 features an "easy loading" printer, for easy paper roll replacement.

- ☛ **Switch the terminal off before doing this operation.**
- ☛ **Don't touch the printer mechanism. Take care the paper cutter is very sharp and the printer could be very hot !**
- ☛ Open the lid of the terminal by pushing the button towards the rear, which opens the lid,
- ☛ Remove the remaining roll of paper,



- ☛ Insert the new roll of paper as indicated on the photo,



- ☛ Press the terminal lid to close.



3 Installation and starting

3.1 Location of the terminal and the base

The ideal place for the base is in the centre of the zone to be covered with a large open area around. The inside antenna is on the left side.

It's mandatory to avoid docking the terminal on a metal surface and to place the hand under the printer during a communication, the range is strongly reduced.

Also, a great vertical metal plane close the base (doors of refrigerator, large home appliances, vending machines) can reduce the range distance.

If there are several Bluetooth technology bases it is necessary to position them at least 2 metres from each other.

Last point, equipment such as Home cordless telephones, cellular phones, can emit harmonics which could disturb the terminal at 2,45 Ghz.

Some Microwave ovens disturb the 2,45 Ghz ISM Band. Don't place the base or the terminal at less than 3 m of any microwave oven in use.

Place the terminal on its base on a clear, flat surface near an electric socket and a telephone socket.

The terminal should be placed far from any very hot zones, protected from vibrations, dust, damp and electromagnetic radiation (computer screen, micro-wave oven, anti-theft barrier etc.).

Bluetooth technology Regulations:

Please check your country regulation about the 2,45Ghz ISM band.

The I7780 system uses 20dBm (100mW) Bluetooth technology which requires no license and which is free of declaration in almost the whole EEC.

Bluetooth technology Regulations (December 2002)

	Indoor	Outdoor
France	10 dBm until 31/12/03 20 dBm since 01/04	4 dBm until 31/12/03 10 dBm since 01/04
Italia	10 dBm	10 dBm
Germany	20 dBm	20 dBm
UK	20 dBm	20 dBm
Spain	20 dBm	20 dBm
Australia	20 dBm	20 dBm
Canada	20 dBm	20 dBm
US	20 dBm	20 dBm
Brazil	20 dBm	20 dBm

Operating temperatures

+5°C to +40°C.

Humidity

20% to 90% without condensation.

Storage temperature





-10°C to +60°C.

3.2 Battery set up and charging

Your terminal is supplied with a removable rechargeable NIMH (optional Lithium-ion) battery. This battery recharges when the terminal is placed on its base. Only use the battery pack supplied with your terminal.

☛ Ensure that the terminal is seated securely on the base.

Battery charge status is indicated by the battery icon  (See diagram page 9).

-  1 bar represents 25 % energy left,
-  2 bars represent 50 % energy left,
-  3 bars represent 75 % energy left,
-  4 bars represent 100 % battery capacity.

☛ Remember to switch the terminal off before you handle the battery pack.

- ① *When you charge the battery for the first time, we suggest you charge it for a period of 3 hours and then check that the charge icon, located on the right hand side of the terminal screen, indicates 100% charge (4 bars). Full charging time after the first time is 2 hour*s.*
- ① *You can carry out up to 200 transactions with a fully charged battery (depends on the ticket size and transaction duration).*
- ① *It is an intelligent management battery, which contains internal charge control. When the terminal is placed on the base, it will only recharge if necessary. Furthermore, the battery has internal temperature control. It never exceeds 50°C.*

* The recommended battery charging time is for a 25°C ambient temperature.

Installing the battery pack

⚡ **Don't touch the terminal on battery connectors**

☞ Hold the battery with the connectors facing downwards,



☞ Position the battery lugs in the two terminal housings,



☞ Press the battery to close; you should hear a "click".



3.3 Terminal connections

All the Ingenico 7780 connections are made via the base.

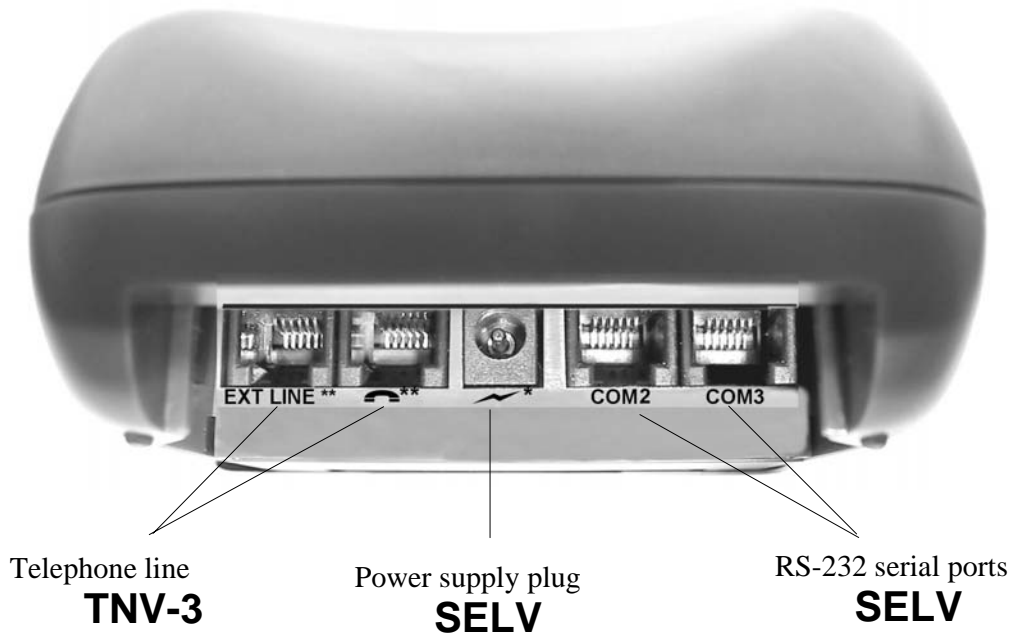

- * **SELV** : Separated Extra Low Voltage
- ** **TNV-3** : Telecommunication network voltage

- ⚡ The power supply socket and telephone socket should comply with applicable standards. Ask your installer for advice.
- ⚡ Connection to the electric network should be carried out last when the telephone or any peripherals have been connected.
- ⚡ Maximum length of cable: 2m50

Connection to the Switched Telephone Network (STN)

Connect the telephone cable connector (supplied with the terminal) to the socket marked  and connect the other end to the telephone wall support.



Telephone line [TNV-3**]

Connecting a telephone to the base

Connect the telephone cable connector to the socket marked with the symbol **EXT LINE**.



↑
Telephone line extension [TNV-3**]

☛ All options are not available for the Ingenico 7780 model.

Connecting to a peripheral

Switch the base off and connect the peripheral cable to the base on the RS232 input/output marked COM2 or COM3.



↑ ↑
Serial links [SELV*]

Connecting to the electric network

Connect the power supply unit connector to the socket marked with the symbol  and the power supply unit to the electric network.



↑
Power supply [SELV*]

ⓘ *An green light, located on the front right hand side of the base, indicates if the power is on.*



ⓘ *A cable securing plate supplied with the terminal keeps the cables in place.*

↑
Cable securing plate



Power supply

- Power supply unit supply voltage 230 VAC
- Frequency 50 Hz
- Voltage output 18 VDC-0.7A to 21 VDC-0,6A



RS232 COM2 and COM3 Interface

- Logic levels (RS 232C levels)
- speed: 300 to 115200 bauds
- format: 7 or 8 bits
- parity: odd, even, none
- flow control: RTS/CTS lines on COM3
- power for external device: 6V to 31V (not regulated) 0.6 W max

#	Com 2	Signal	Com 3	Signal
1	Power	→	Power	→
2	Tx_Com2	→	Tx_Com3	→
3	Rx_Com2	←	Rx_Com3	←
4	Rts_Com2	→	Rts_Com3	→
5	Cts_Com2	←	Cts_Com3	←
6	Ground	↔	Ground	↔

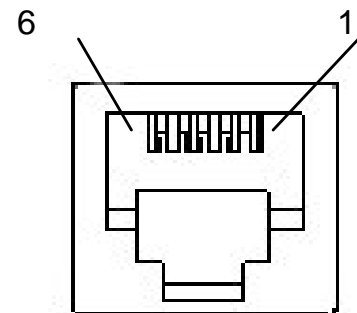

Telephone line

#	Line	Line extension
1	Non connected	Non connected
2	Line 2 (option)	Non connected
3	Line 1	Line 1
4	Line 2	Line 2
5	Line 1 (option)	Non connected
6	Non connected	Non connected

Bluetooth technology communication

- Type 20 dbm hopping frequency
- Bandwidth ISM 2,45 GHz
- Emitting power ≤100mW (20dBm)
- Range ≈ 200 meters (open field) after the research phase (Bluetooth technology icon present)

3.4 Installing a SIM card and a full format card

The SIM card and full format card connectors are located in the battery compartment located under the terminal.

⚡ **Don't touch the terminal on battery connectors**

Installing the SIM card

- ☞ Remove the battery,
- ☞ Unlock the connector by sliding the metallic part in the direction of the **OPEN** arrow,
- ☞ Lift the card housing up,
- ☞ Insert a SIM card into the housing,
- ⚡ **Make sure you put it in the right way, follow the foolproof lug!**
- ☞ Put the housing back down again,
- ☞ Lock the connector by sliding the metallic part in the direction of the **LOCK** arrow.

Removing the SIM card

- ☞ Follow the installing instructions to remove the SIM card

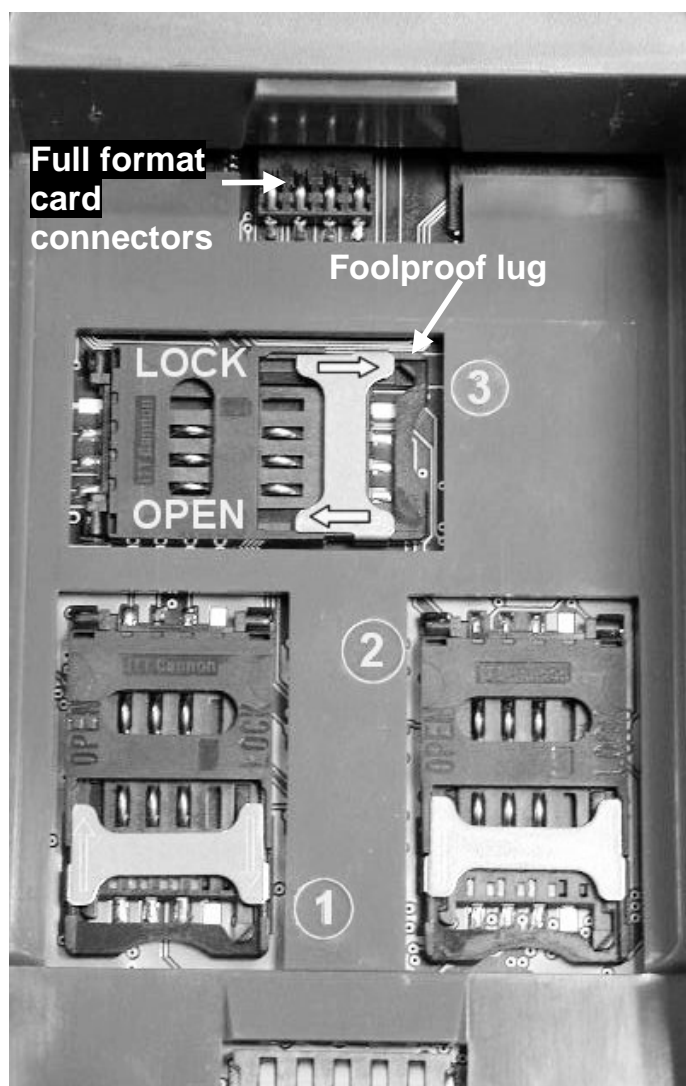

ⓘ *With SIMcards it is possible to access different services and to add new functions to the terminal. For example, a SIM card will be supplied by the bank manage the Moneo electronic purse.*

Installing the full format card

- ☞ Remove the battery,
- ☞ Slide the card into the housing connector to connector,
- ☞ Put the battery pack back in place; the battery pack keeps the off-the-shelf board in position.

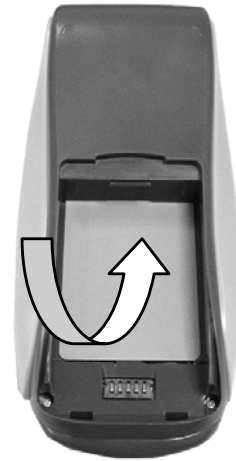

- ⓘ *The full format card is used to identify the trader. This card is required for certain applications.*

3.5 Troubleshooting

The terminal does not turn on

- ☞ Check that the battery is charged (see chapter 3.2 “Battery set up and charging”).
- ☞ Check base and wall support connections (both electric and telephone connections).

You cannot connect to the telephone network

- ☞ Check base and wall support connections (both electric and telephone connections).
- ☞ Check that the terminal is placed on the base correctly {check that the terminal displays (on the right hand side of the display) the connection to the base symbol  }.

There is nothing on the receipt that comes out of the terminal

- ☞ Check that the roll of paper has been put in the right way (see chapter 2.3 “Changing the roll of paper”)

There is no Bluetooth technology link between the terminal and the base

- ☞ Check that the terminal is in the Bluetooth technology field (the terminal displays this icon  on the upper left hand corner of the screen.
- ☞ Check if any other system used, using frequently the ISM 2,45 GHz band is connected.

4 Recommendations

4.1 Security

Your terminal fulfills the VISA security requirements, as well as high security requirements from Northern European and Asia-Pacific zone.

In order to ensure that software integrity self-test is performed periodically, it is necessary to restart (disconnect-reconnect) the terminal at least once per day.

4.2 Safety

As this terminal does not have a power off switch, the disconnecting device is the main transformer; the power supply plug must therefore be easily accessible.

Safety directives concerning the Lithium batteries

- Keep out of the reach of children.
- If any elements of the battery are swallowed, the person should consult a doctor or seek medical assistance immediately.
- It is important to comply with the "+" et "-" polarities.
- Do not try to reactivate the batteries using a heat source, an electric recharge or any other means.
- Do not throw the batteries into the fire.
- Do not dismantle the batteries.

Safety directive concerning Ni-Mh batteries

- Keep out of the reach of children.
- Do not heat or throw into the fire.
- Do not short-circuit the batteries.
- Do not block the safety valves (located under the positive terminals).
- Do not use in a hermetically sealed box.
- Only use the supplied charger and within the specified temperature.
- Do not handle or use the battery again if it has been damaged or if there is any liquid leaks.

Generally speaking

- Ensure that the terminal is seated securely on the base.
- There is a danger of explosion if the battery unit or battery has not been replaced correctly.
- Replace the batteries and battery unit with same type elements or similar type elements recommended by the manufacturer **only**.
- Dispose of used battery units and batteries in compliance with manufacturer instructions.
- Do not throw the batteries and battery unit into the bin; dispose of them in suitable recycling facilities.

4.3 Switched Telephone Network (STN)

This equipment has been certified according to the 98/482/EC decision made by the Pan European committee concerning the connection of equipments to the switched telephone network. The certification does not however provide unconditional assurance of optimum operation when connecting to the telephone network.

If you encounter any difficulties, contact your dealer or installer first.

4.4 RF Safety

In-car safety

The use of the terminal in a vehicle may cause malfunctions of electronic systems (e.g. ABS anti-lock systems, fuel injection systems) particularly in insufficiently shielded systems.

Exposure to RF Energy

There is some public concern about the possible health effects of using cellular equipment. Although research on health effects from RF energy has focused for many years on the current RF technology, scientists have begun research on newer Bluetooth technology technologies. After existing research had been reviewed, and compliance to all applicable safety standards had been tested, it has been concluded that the product is completely safe to use.

4.5 General safety

Electronic Device

Most electronic equipment, for example in hospitals and motor vehicles, are shielded from RF energy. However, RF energy may affect some damaged or improperly shielded electronic equipment.

Vehicle Electronic Equipment

Check with your vehicle manufacturer's representative to determine if on board electronic equipment is adequately shielded from RF energy.

Medical Electronic Equipment

Consult the manufacturer of any personal medical devices (such as pacemakers, hearing aids, etc.) to determine if they are adequately shielded from external RF energy.

Turn your Terminal OFF in health care facilities when any signs in the area instruct you to do so. Hospitals or health care facilities may be using RF monitoring equipment.

Aircraft

 **Warning: Turn your Terminal OFF before boarding any aircraft, use on the ground only with the crew's permission. Do not use it in the air.**

Children

Do not allow children to play with your terminal. Children could hurt themselves or damage the terminal.

Blasting areas

To avoid interfering with blasting operations, turn your unit OFF when in a "blasting area" or in areas posted: "turn off two-way Bluetooth technology". Construction crews often use remote control RF devices to set explosives.

Potentially Explosive Atmospheres

Turn your terminal OFF when in any area with a potentially explosive atmosphere. It is rare, but your terminal could generate sparks. Sparks in such areas could cause an explosion or fire resulting in injury or death.

Areas with a potentially explosive atmosphere are often, but not always marked. They include fuelling areas such as petrol stations, below decks on boats, fuel or chemical transfer or storage facilities, and areas where the air contains chemicals or particles, such as grain, dust, or metal powders.

Do not transport or store flammable gas, liquid, or explosives, in the same compartment as your terminal.

Before using your terminal in a vehicle powered by liquefied petroleum gas (such as propane or butane) ensure that the vehicle complies with the relevant fire and safety regulations of the country in which the vehicle is to be used.

4.6 WEEE

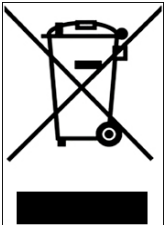

This symbol on the product or on its packaging means that this product should not be treated as household waste.

To minimise environmental impacts and the disposal of waste, this product should be handed over to a separate collection system in order to facilitate recycling and recovery.

For more detailed information, please contact your reseller.

5 Index

B

Battery9, 14

C

Card reading 11
Charge..... 14
Connecting a telephone to the base..... 17
Connecting peripherals..... 17
Connecting to the electric network 17
Connections 16

F

Full format card 19

I

Installing the battery pack 15
Installing the SIM card 19

M

Magnetic stripe card..... 11

P

Paper roll 12
Power supply..... 18

R

Removing the SIM card..... 19

S

SIM..... 19
Smart card 11

NON CONTRACTUAL DOCUMENT

INGENICO owns exclusive rights on this document.

All diffusion, all copies, all entire or partial production by any process, as long as it is made without the authorization of INGENICO, the promoter, will be considered as illicit, and will form an infringement, penalized by the clauses L.335-2 and following, of the « Code de la propriété intellectuelle ».

INGENICO keeps the right without notice to modify the characteristics and the functions of this device.

INGENICO is not responsible for any use of this device, which would be non consistent with the present document.

Your contact

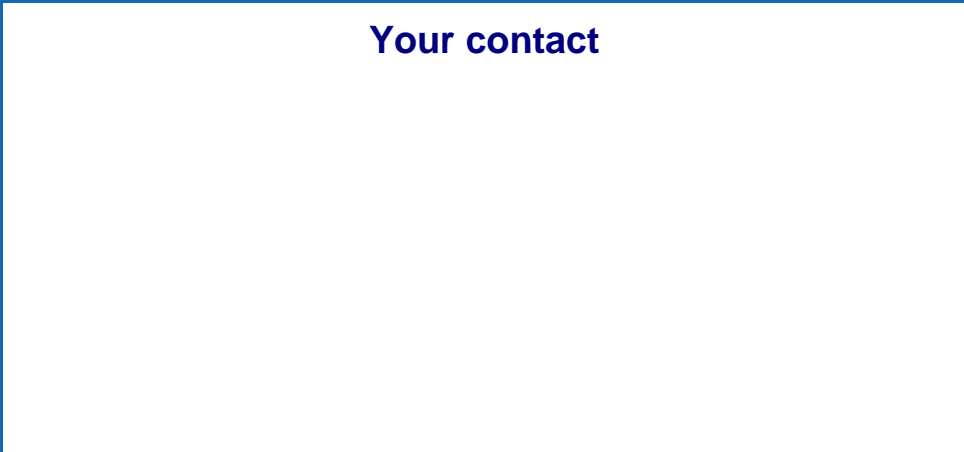

Ingenico

192 avenue Charles de Gaulle

92200 Neuilly sur Seine_France

Tél. : 01 46 25 82 00 - Fax : 01 47 72 56 95

www.ingenico.com

DIV0761D